

**GH15 GLORY HOLE
TECHNICAL SPECIFICATIONS**

- Gas inlet 3/4" NPT
- 1psi natural gas
- 1/2 psi propane,
- 300KBtu/hr

- Electrical 120VAC, 6 amps
15 amp breaker

- Maximum temperature: 2450F

- Weight: 900 lbs
Shipping Weight: 1,050 lbs

- Clearance: provide at least 36"
clearance to side of control panel

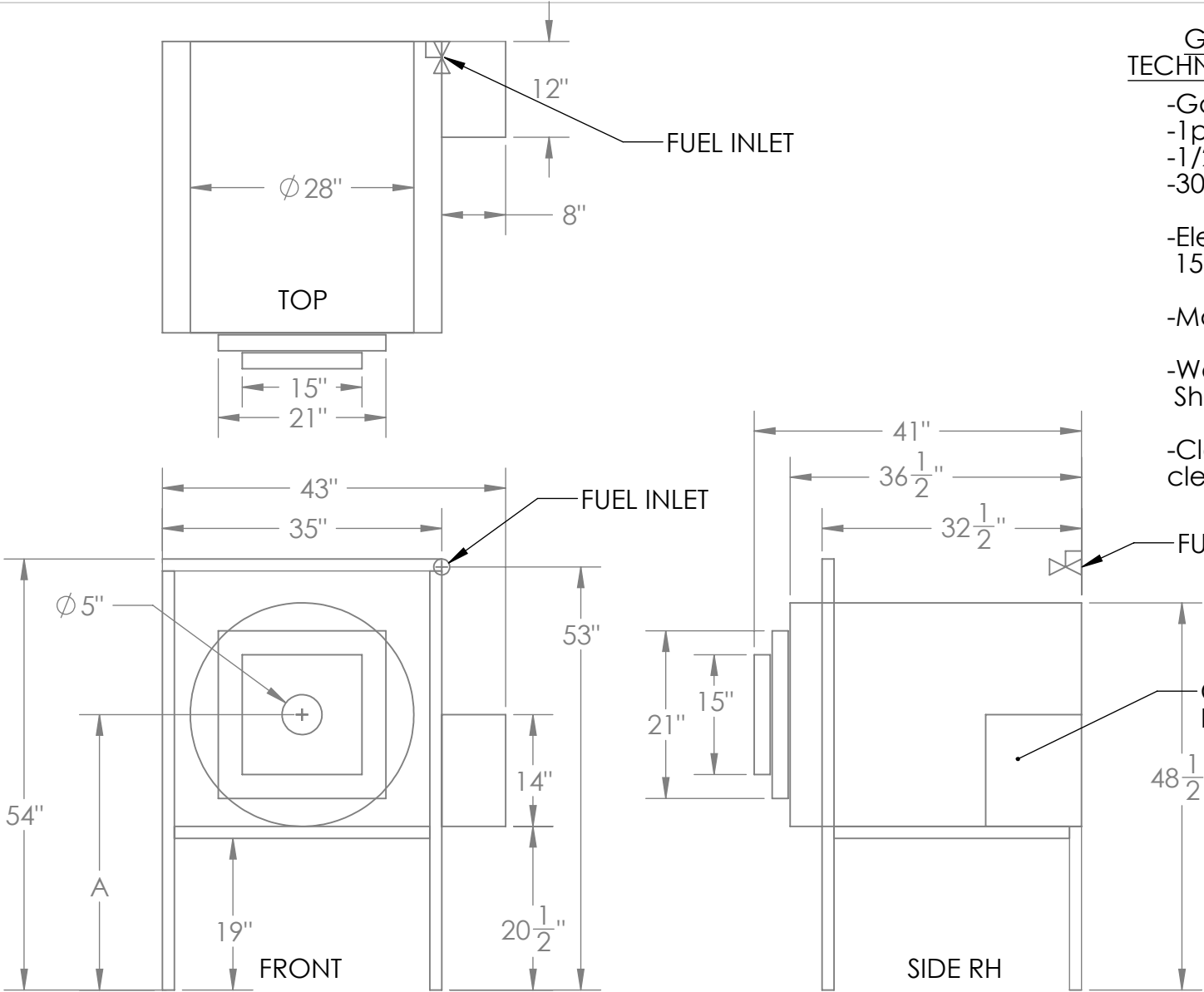

NOTE: DIMENSION A IS ADJUSTABLE FROM 33" TO 35"

A	COPY	SCALE: 1:20	04-22-09	DLB
	SHEET 1 OF 1		DATE	DRAWN BY

PROPRIETARY STATEMENT
THIS DESIGN IS COPYRIGHT PROTECTED. ANY UNAUTHORIZED FABRICATION AND SALE OF THIS PRODUCT OR ITS DESIGN IS STRICTLY PROHIBITED, AND VIOLATORS WILL BE PROSECUTED TO THE FULL EXTENT OF THE LAW.

100-C RUSSELL DR.
STAR, N.C. 27356
P.O. BOX 96
Ph. 910-428-4111
Fx. 910-428-4123



TITLE	GLORY HOLE
	GH15
DWG	TOLERANCES: FRACTIONS= ± 1/16", .X= ±.1, .XX= ±.03, .XXX= ±.005, ANGLES= ± 1DEG.
	GH15 PURCHASE SPECS